

General instruction manual

for thermoline plate heat exchanger

thermowave
Gesellschaft für Wärmetechnik mbH

Eichenweg 4
06536 BERGA
GERMANY

Phone: +49 34651 418-0
Fax: +49 34651 418-13
Email: thermowave@thermowave.de
Internet: www.thermowave.de

F.a.o. All Owners and Operators

Dear Customer,

You have decided to buy a quality product from **thermowave GmbH**, manufactured according to PED 97/23 (EC).

Your plate heat exchanger is a capital investment developed under consideration of the latest research results. The individual components are state of the art and enable a high degree of functionality and reliability.

On the following pages you will find an instruction manual for your plate heat exchanger, which takes into consideration the requirements of PED 97/23 (EC). This instruction manual contains all the important measures for smooth operation of your plate heat exchanger. Ensure that all persons who are involved in the installation, operation and servicing of the apparatus are aware and have understood the contents of this instruction manual.

thermowave GmbH cannot accept responsibility for faults which are incurred due to failure to comply with the instructions given in this instruction manual. Please contact **thermowave GmbH** or your local representative immediately if you experience problems with your plate heat exchanger, which are not dealt with in this instruction manual.

We wish you every success and pleasure with the operation of your **thermoline** plate heat exchanger.

Your partner for the solution to your heat transfer problems.

thermowave
Gesellschaft für Wärmetechnik mbH

Contents

I. Important Information	4
1. Instruction Manual	4
1.1 Use of the instruction manual	4
1.2 Scope of the instruction manual	4
2. Safety Information	4
3. Intended Purpose	6
4. Name Plate.....	7
II. The Plate Heat Exchanger	8
1. Construction	8
2. Method of Functioning	8
3. Heat Exchanger Plate Differentiation.....	9
4. Dimensioned Drawings and Plate arrangement.....	11
5. Frame	11
6. Safety Plate	11
III. Handling the Plate Heat Exchanger before Start Up	12
1. Delivery.....	12
2. Transport / Erecting	12
3. Installation	13
IV. Operating the Plate Heat Exchanger	17
1. General.....	17
2. Starting Up.....	18
3. Withdrawal from Service.....	18
4. Shutdown.....	18
5. Re-Commissioning (Following Shutdown)	19
6. Service and Maintenance	19
7. Defects Analysis	21
V. Installation and Removal of the Plate Pack	23
1. Opening the Plate Pack.....	23
2. Removing the Plates.....	23
3. Installing the Plates	24
4. Closing the Plate Pack.....	24
VI. Cleaning	27
1. General.....	27
2. Cleaning Laser Welded Modules.....	27
3. CIP – Reinigung (Cleaning in Place)	28
4. Manual Cleaning.....	28
Appendix Z: Plate Heat Exchanger Documentation	

I. Important Information

1. Instruction Manual

1.1 Use of the instruction manual

All persons who are employed with the installation, operation, servicing and possible repair of the plate heat exchanger must confirm to the owner/user, in writing, that they have read and understood this instruction manual.

Ensure that the instruction manual is handed to the operating personnel for constant availability.

Particular attention must be given to the **Safety** section!

1.2 Scope of the instruction manual

The information given in this instruction manual **only** applies for the plate heat exchanger, whose fabrication number is given on the title page and on the name plate of the apparatus (see Chapter I.4).

In case of queries and spare parts orders, please ensure that you always quote the fabrication number.

This instruction manual applies both for gasketed plate heat exchangers as well as for plate heat exchangers with laser welded modules.

2. Safety Information

Plate heat exchangers are devices which are partly run with corrosive and / or toxic media and /or at high pressures and temperatures.

Therefore, when using the heat exchanger ensure that you always

Put Safety First!

To this end, please observe the following **instructions**:

- Only run the apparatus according to its intended purpose (see Chapter I.3).
- Ensure that you always wear suitable work gloves when handling the plates. There is a high risk of cuts due to the thin thickness of the metal plates!
- Only start up the apparatus after you have checked whether the tension matches the details given on the name plate and all the available protective covers have been installed. The insulation hoods are also protective covers.
- During installation and service works, ensure that you take into account the overturning moment. If the apparatus is not permanently and securely installed, use suitable fixings to plant parts or structures to secure it against tipping up.
- Only open the apparatus after it has been depressurised and after the ambient temperature has been reached.

Caution!

The surface temperature of the frame plates and especially the heat exchanger plates can absorb the operating temperature of the media flowing in the apparatus!

- Leave the safety devices e.g. drip trays, protective covers, insulation hoods, safety valves or similar in place so that it can fulfil its function.
- In order to prevent injuries caused by the apparatus' sharp-edged heat exchanger plates the plate pack must be fitted with a safety plate or other suitable protection against access or contact.
- Damaged plates or gaskets must be replaced with new parts and must not be re-installed.
- Only use original spare parts from thermowave. The use of parts not approved by thermowave can lead to faults and cancels the guarantee.
- Anchor the plate heat exchanger to the points in the ground provided or to fixed building or plant parts.
- Ensure that unauthorised persons have no direct access to the apparatus.
- Never run the plate heat exchanger in a hazardous environment. A caustic atmosphere, caused e.g. by ozone producing equipment, can lead to damage to the gaskets and to leaks. If necessary contact thermowave.
- Protect yourself against the consequences of a plate rupture by using suitable equipment to monitor the transfer of media from one side to the other.
- Keep the area around the apparatus clean; soiled areas are often the cause of accidents.
- Only carry out service and repair works if
 - all the pumps have been switched off and secured against accidental start up,
 - the apparatus is depressurised,
 - and the apparatus' temperature has reached the ambient temperature.
- In case of fire, the gaskets used in the plate heat exchanger can burn out or melt, which leads to media leakages. If these are combustible, there is an increased risk of fire or the spread of a fire. Therefore, if combustible media are used, ensure you take suitable preventative fire protection, fire alarm, fire extinguishing measures and measures for switching off the plant.
- Any material is subject to deterioration and wear, depending on the operating conditions. Plate breaks can therewith not be entirely excluded. Media mixes could possibly be the result. You are therefore asked to care for a leakage detection system, adapted to the sensitivity of the used media.
thermowave assumes no liability for possible consequential loss when an efficient protection system against leakages is missing.

3. Intended Purpose

A plate heat exchanger is not a universal or multi-purpose apparatus. It is designed for use with certain media, pressures, temperatures, operating characteristics, etc. The application limits are given on the name plate, which is usually located on the fixed frame plate.

Ensure that your heat exchanger is only operated within the aforementioned application limits.

In case of changes to the original operating mode or on reaching the minimum initial measure (=final measure), please contact the customer service department at:

thermowave GmbH
Abt. Kundendienst
Eichenweg 4
06536 BERGA
GERMANY
Tel.: +49 34651 418-16
Fax: +49 34651 418-13
Mobile: +49 172 7984380

The plate heat exchanger is sensitive to large changes in operating conditions. Therefore, please ensure that sudden pressure and temperature changes do not occur.

Temperature changes up to 1 K/s and pressure change rates up to 2 bar/s are deemed to be safe. This limitation does not include process temperature changes during CIP cleaning of the plate heat exchanger. If any other deviations occur, please ensure you contact thermowave.

Only run the apparatus when it is in a technically perfect condition. Ensure that it is used as prescribed, with full awareness of the safety requirements and possible risks and have any faults which can affect the safety of the apparatus corrected immediately!

Use as prescribed also includes observing the instruction manual.

Any warranty claim expires when it comes to damages that could have been avoided by taking this instruction manual into consideration. thermowave assumes no liability for consequential losses, which can definitely be attributed to neglect with regard to the instruction manual.

The pressure retaining components are designed under consideration of the cyclic stress of ≤ 1000 starts/ shut downs for the intended operating mode.

No welding work or heat treatments or any other work which could contribute to weakening of the material may be carried out on the pressure retaining parts of the plate heat exchanger. **Moreover you must ensure that welding current may not be conducted over the plate heat exchanger.** During the installation and assembly the plate heat exchanger may only be fixed to the devices provided (angles, bottom fixtures). Additional loading, e.g. due to connected pipes or other components, must be avoided.

The pressure retaining parts, such as tightening bolts and frame plates, which do not come into contact with the media, do not contain any allowance for corrosion.

4. Name Plate

A name plate is usually located on the fixed frame plate of your plate heat exchanger in accordance with Figure 1. If the apparatus is fitted with an insulation hood, a second name plate is located on one of the external sides of the insulation hood or an additional name plate is enclosed with the apparatus. Please fix this to the insulation in a suitable way so that it cannot be removed.

If the name plate becomes illegible during the service life of the apparatus, please contact **thermo-wave** for a replacement, remembering to quote the fabrication number.

The name plate contains all the relevant data for your plate heat exchanger.

Compare the fabrication number on the name plate with the number on the cover sheet of this instruction manual. The information given in this instruction manual is only valid if the two numbers are the same.

Ensure that the operating data given on the name plate is complied with at all times.

CE



Gesellschaft für Wärmetechnik mbH
Eichenweg 4, D-06536 Berga
Tel.: +49 34651 418-0

Kennnummer der Benannten Stelle:
No. of notified body:

Plattenwärmetauscher
Plate heat exchanger

Fabrikationsnummer / Baujahr
Fabrication No. / Year of construction

Anfangs- /Endmaß 
Initial / final dimension

Leermasse [kg]
Weight empty [kg]

Kategorie
Category

Raum Chamber	Medium Medium	Inhalt Volume [L]	Zul. Druck Perm. pressure PS [bar g] Min / Max	Zul. Temperatur Perm.. temperature TS [°C] Min / Max
			/	/
			/	/
			/	/
			/	/

Vor Installation Betriebsanleitung lesen!
Read operating instructions before installation !

II. The Plate Heat Exchanger

1. Construction

thermoline plate heat exchangers consist of corrugated shaped plates, which are clamped together between a fixed and a movable frame plate using tightening bolts so that they can be removed and are arranged between the upper and lower carrying bar. The carrying bars serve as a guide bar for the heat exchanger plates and form the connection between the frame plate and the support. The connections for the media and any purging and draining equipment required are located on one or two frame plates.

Refer to the drawing (Appendix Z) to see where the connections are located in your apparatus.

Plates with gaskets and welded modules with various corrugation patterns are available for all kinds of different applications. The media can be directed in parallel and counter flow. In the case of large differences in flow capacities on the primary and secondary side and to achieve lower final temperature differences it is possible to allow the media involved in the heat transfer process to be used several times by changing its direction. In such apparatus the connections for the media are not only on the fixed frame plate but on the movable one too.

Media and temperature resistant gaskets, glued or adhesive-free, are used to seal the flow channels according to the operating conditions.

The welded plate module forms a flow channel sealed off from the outside by a laser weld. The transfer from one module to the next is sealed by ring gaskets made of special materials and with a high loading capacity.

thermoline plate heat exchangers are mainly constructed from standardised individual parts. Due to its extraordinarily flexible construction tailor-made customer solutions can be produced by means of an appropriate combination of plates, gaskets and frame components. Subsequent modifications to the operating conditions, e.g. which require an extension of the plant can mostly be realised without any major difficulties.

2. Method of Functioning

The media involved in the heat transfer are fed to the plate pack via connections on the fixed and movable frame plate. The parallel arrangement of the plates creates channels for the distribution of the media in the gaps between the plates and for removing them from the heat exchanger.

The media flow through the plate gaps depending on the arrangement / design of the apparatus in parallel or counter flow. At the same time heat is transferred from the hotter to the colder medium. Due to the turbulent flow this heat transfer takes place much more effectively than in other heat transfer constructions.

Plates with different corrugation patterns can be combined so that the permissible pressure drops available are optimally utilised. Due to the installation of divider plates the media can be fed through the plate gap several times and so take part in the heat transfer process longer. This very high NTU values can be achieved in a compact apparatus.

3. Heat Exchanger Plate Differentiation

For orientation when installing the heat exchanger plates they are labelled as right-hand and left-hand plates (see Figure 2). To this end the letter R (right-hand) or L (left-hand) is punched into the top edge of the plate near to the cutout for the carrying bar. If you look at the plate from the direction of the gasket side, the relevant letter for the respective plate side can be read from the correct side.

The plates are mounted on the carrying bar beginning at the fixed frame plate and with the gasket side facing it.

Each plate pack begins with a starter plate which differs from the following plates due to a special arrangement of the ring gaskets. It must usually be ensured that a ring gasket is fitted for every 4 plate openings. When connecting the media to the moveable frame plate special attention has to be paid to the position of the end gasket. Here too, a ring gasket is required for each plate opening. In the case of complicated plate arrangements (e.g. multiple apparatus), you should contact **thermowave's** customer service department when changing the gaskets.

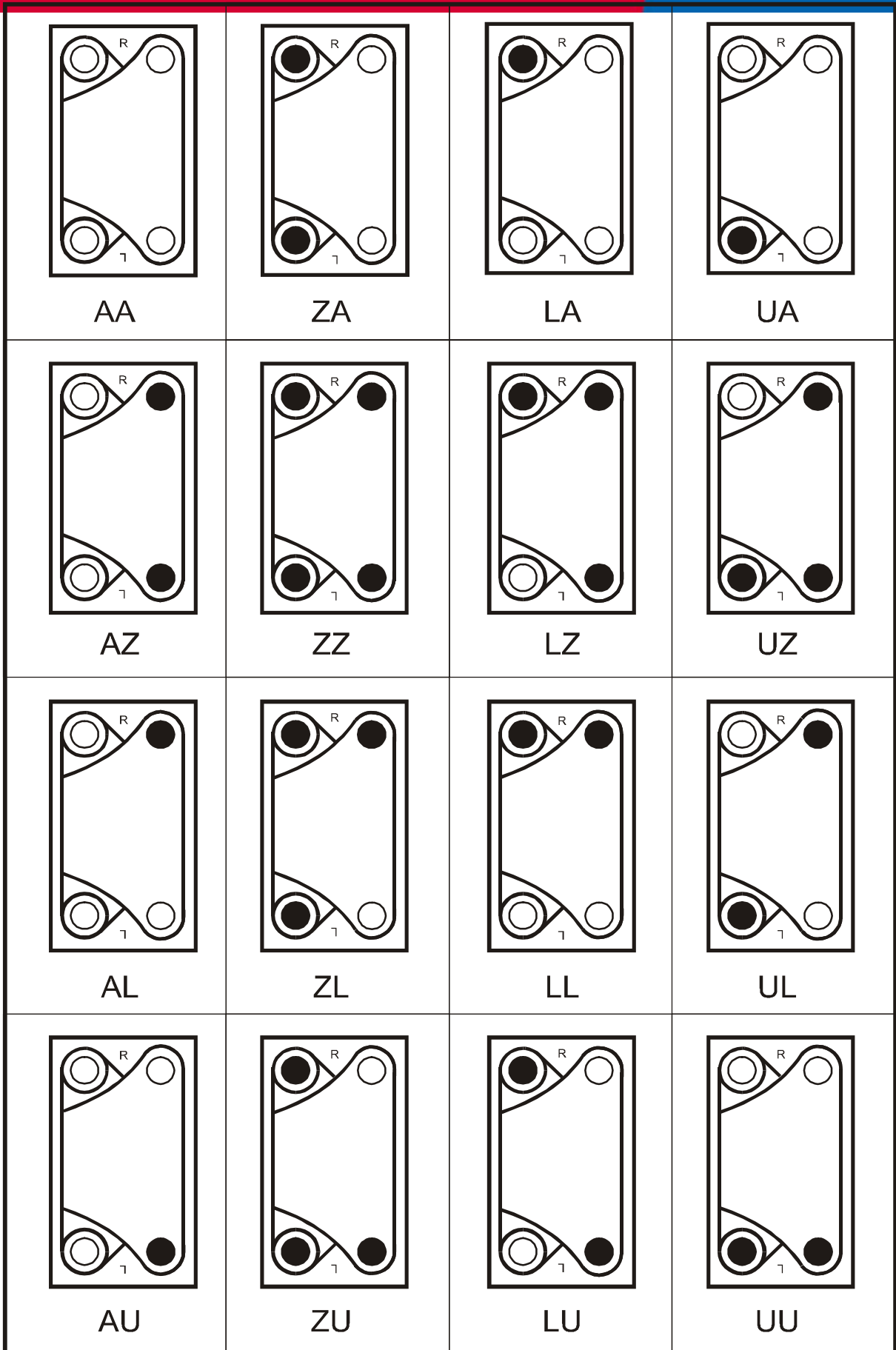

BA AA 0 ● EN 00 04 Closed opening

○ 10 Open opening

Figure 2

4. Dimensioned Drawings and Plate Arrangement

A product data sheet, a dimensioned drawing and a parts list is produced for each **thermoline** plate heat exchanger. These documents are issued to the customer together with the delivered apparatus. The dimensioned drawing shows the most important dimensions of the apparatus and the dimension, type and position of the pipe unions.

The parts list with the switching provides information about how the individual plates are arranged within the apparatus.

5. Frames

thermoline plate heat exchangers are available with different frame designs.

Apart from the K and N frame designs, optimised for after sales purposes, one frame model has a very low design (T-shaped), and for the apparatus models TL 50 / TL 90 / TL 150 with a low number of heat exchanger plates, one frame model is available without front supports (H-shaped).

thermowave supplies standard frames painted in RAL 5018. Other shades or special materials are carried out according to the customer's order specifications.

For a complete explanation of the nomenclature used for our frames, please refer to Appendix A.

6. Safety Plate

When using poisonous or combustible media or media which encourages fires or causes other possible risks to people and plant, the plate pack must be designed with a safety plate. Furthermore, above working temperatures of 50 °C the apparatus must be fitted with an insulating hood or a safety plate. If the apparatus is accessible for employees other than instructed skilled personnel, the plate pack should be fitted with a safety plate or another suitable form of protection against access or contact to protect against injuries.

Please only ever remove this plate when the apparatus is at a standstill and depressurised and has reached the ambient temperature!

III. Handling the Plate Heat Exchanger before Start Up

1. Delivery

Depending on its size, the plate heat exchanger is delivered flat or upright. The accessories are usually packed separately and enclosed with the apparatus.

Please use the enclosed packing list or delivery note to check the completeness and integrity of the delivery.

Transport damages must be noted on the carrier's consignment note and the delivery note. Please report any missing or damaged parts immediately to

thermowave GmbH
Versandabteilung
Eichenweg 4
06536 BERGA
GERMANY
Tel.: +49 34651 418-38
Fax: +49 34651 418-13.

The dispatch department will receive your notification and will assist you to solve the problems.

2. Transport / Erecting

The plate heat exchanger must be slung with suitable equipment (round slings, ropes, etc.) and at the available clevis type eyelets (see Figure 3) and lifted using the transport equipment. Chains must not be slung directly around the apparatus, as this can damage the apparatus and there is a risk of it slipping.

The lifting gear must only be passed under the plate heat exchanger while its packaging is still on.

A crane or a fork lift with an adequately dimensioned permissible load-bearing capacity must be used for lifting. The apparatus must be transported in accordance with Figure 3. It is not permitted to pick up the apparatus by passing the forks of the fork lift truck directly beneath it, either in the longitudinal or the transverse direction.

Please note that the apparatus must be erected slowly and adequate slack given to the slinging materials when placing the machine upright (Figure 4).

Please ensure that you observe all the valid occupational health and safety and accident prevention regulations!

3. Installation

The technical documents for your plate heat exchanger and the assembly data are given in Appendix Z. There you will find details about the weight of the apparatus, the dimensions for fixing it to the ground, etc.

Please check whether the correct apparatus has been correctly tightened before installation. If this is not the case, please contact our Customer Service Department (See Chapter 1.3 for address, phone and fax number).

If the apparatus has been delivered open or with the plate pack separate, you must proceed according to Chapter V.3 or V.4.

The substrate of the place of installation must be checked to ensure that it has an adequate load-bearing capacity, especially for the filled apparatus.

The frames are equipped with two fixing angles on the fixed frame plate and with one fixing angle or a bottom fixture on the support. The apparatus can be fixed with foundation bolts and rawl plugs. When installing on frames, platforms or upper storeys the customer must ensure that a safe anchoring is provided. The dimensioned for the bottom fixture are given in the dimension sheet in Appendix Z. When installing plate heat exchangers on a roof a lightning conductor is required. When installing it outdoors a canopy or protective roofing must be provided. If this is not possible, the apparatus must be covered with a protective plate.

Adequate space must be kept free all round the plate heat exchanger to allow a person to walk around it. A distance of approx. 1.5 m is required between the plate heat exchanger and fixed pipes and sets which are installed to enable assembly and service works to be carried out. In order to be able to open the apparatus, there must be no installations between the movable frame plate and support.

The apparatus is integrated in the pipe network via connections for feeding and removing the media. The counterpart to the connections on the apparatus must be attached to the pipes on site. Nozzles on the plate heat exchanger, which are not connected must be closed tight on site using state of the art means, e.g. as prescribed for refrigeration engineering in DIN 8975 and DIN EN 378. Please refer to the technical documents in Appendix Z for the constructive design of the connections. Valves in the intake and outlet pipes and suitable drain / purging devices in the immediate vicinity of the apparatus are recommended for when service works are carried out on the plate heat exchanger.

For purge and / or oil drainage use the possibly existing connections, please. They are significantly contributing to a failure-free operation of the plate heat exchanger.

When installing the pipes you must ensure that no forces and moments act on the plate heat exchanger connections. If necessary, the inlet and outlet pipes must be propped with pipe holders.

If the connections are fitted with rubber linings, the average guideline values for the bolting torques for the screw connection stay bolts / nuts given in Table 1 must be taken into consideration.

Stud bolts	Average bolting torque for stud bolts / nuts
M 12	20 Nm
M 16	40 Nm
M 20	70 Nm
M 24	110 Nm

Table 1

For connections to the movable frame plate it must be ensured that the pipes are designed so that they can move in the longitudinal direction of the apparatus, so that the plate pack can be tightened if necessary during the running period. The minimum initial measure given in the technical documents and on the name plate (Figure 1) must be maintained at all times. Please contact thermowave if the minimum initial measure is reached (Chapter I.4 for the address).

Additional time and cost during the installation works due to failure to install the plate heat exchanger according to the regulations are the responsibility of the customer, even during the guarantee period. This also includes additional costs due to installations fitted by the customer which hinder movement of the movable frame plate up to the support for inspection purposes. thermowave only provides guarantee services for apparatus which has been properly installed according to the instruction manual.

When using media harmful to the environment, suitable measures must be taken on site to protect the environment against leaking media (e.g. setting up the apparatus in drip trays).
Welding and grinding residues, as well as any other dirt must be kept away from the apparatus.
We can supply suitable protective covers for the plate pack or insulation hoods as protection against working accidents. These protect against unwanted contact and also help to reduce heat losses.
The valid occupational safety regulations and the owner's operating instructions must be observed during all works on the plate apparatus.

Finally, we remind you once again that the apparatus cannot be started up until all the necessary safety devices have been installed.

ATTENTION - only use the clevis type eyelets for transporting!

Tragkraft F
Load capacity F

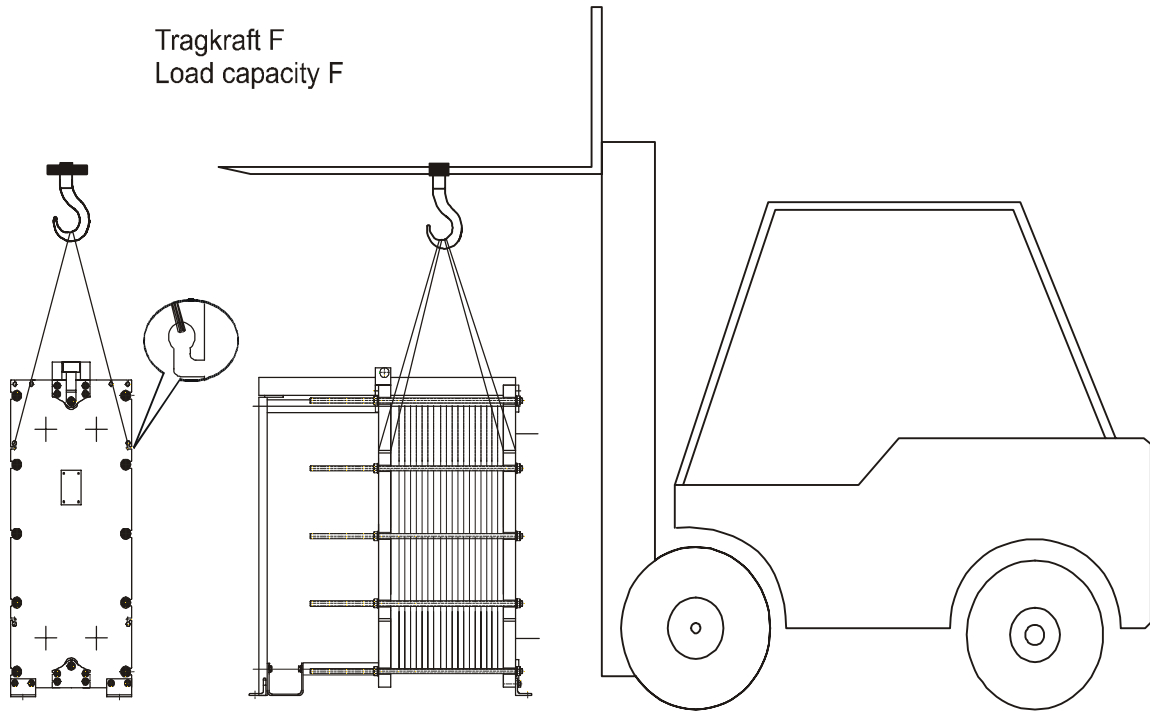

F = mindestens 1,5 x Gewicht des Plattenwärmeübertragers
F = at least 1,5 x weight of plate heat exchanger

Plattenpaket nicht unterfahren!
Don't run under the plate pack!

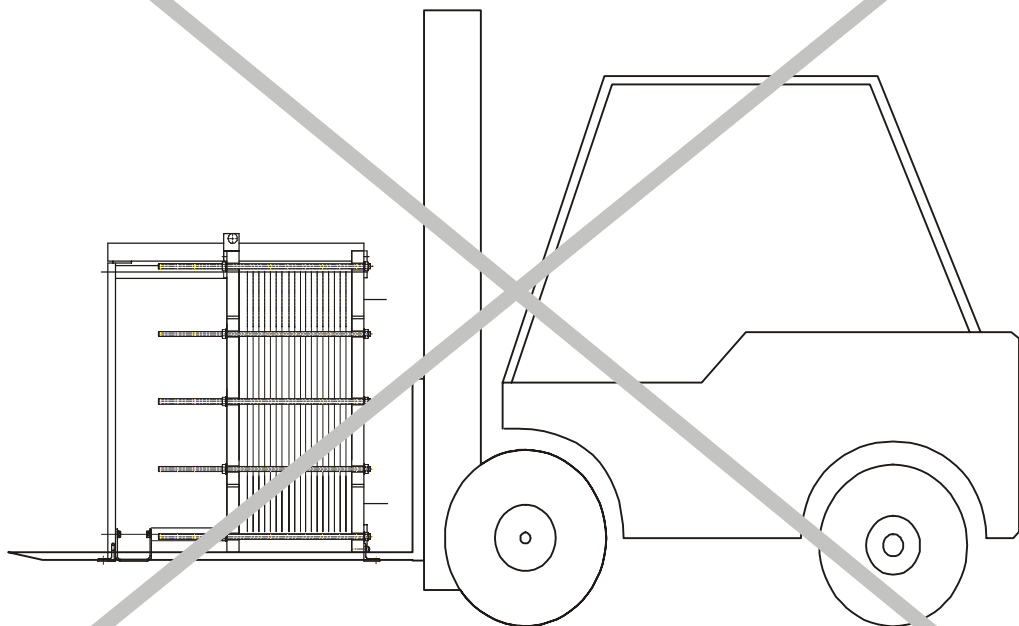

Attention!

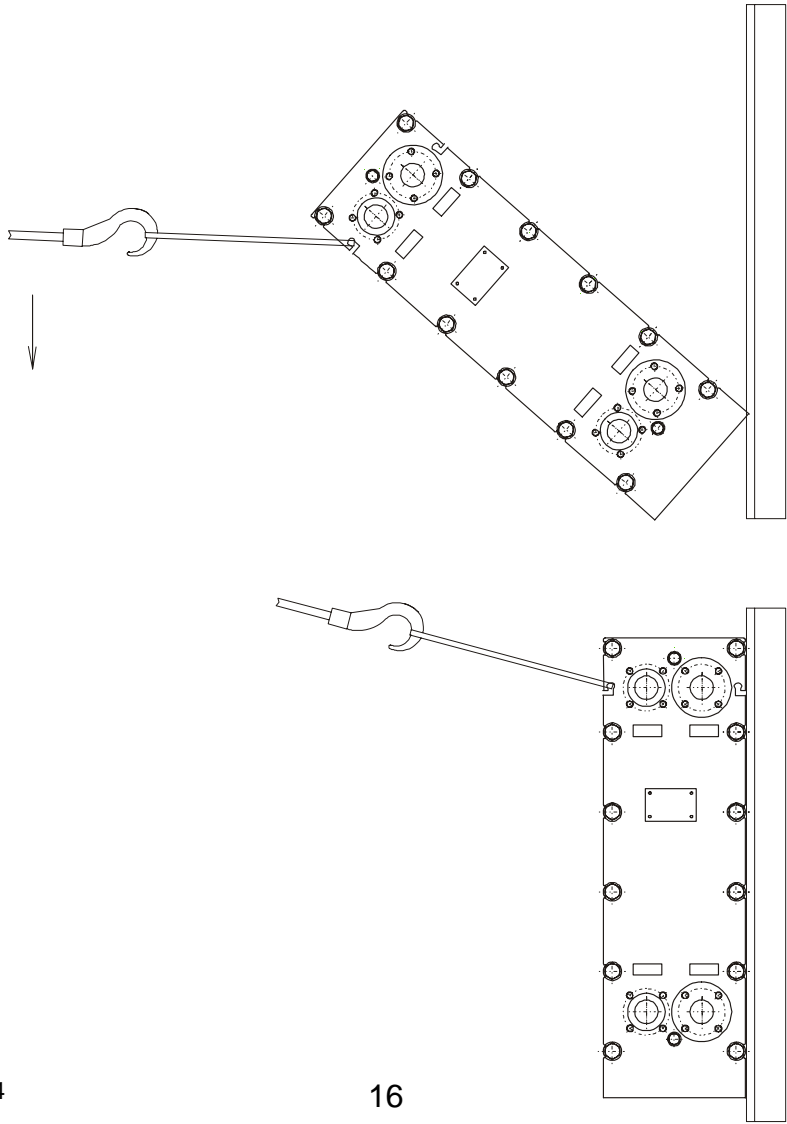

Sling

Stand upright

Transport

Tighten the tightening bolts

Figure 4

IV. Operating the Plate Heat Exchanger

1. General

The plate material has been selected to the best of our knowledge based on the information available to us, however, it must be checked under consideration of the local operating conditions. Our warranty does not cover the resistance of the materials under improper use and handling of the apparatus.

Any corrosion resistance for the heat exchanger plates assured by thermowave in writing for certain applications only applies subject to the prerequisites that

1. a clear and up-to-date, written media analysis has been received before the order is placed and the resistance of the thermowave material has been confirmed in writing for this application,
2. all the media flowing through the plate heat exchanger are subject to constant monitoring with respect to components which can cause corrosion (see DIN 50930, Part 1-5) and the media analyses supplied under 1 are maintained during the monitoring,
3. the results of the investigation in Item 2 are verified at least quarterly,
4. the plate heat exchanger is verifiably and constantly run within the prescribed operating conditions.

Possible risks for humans and the environment must be prevented by suitable safety installations (plate covers, anti-contact protection, insulation, drip tray, etc.). The relevant regulations must be observed where aggressive media or media harmful to water are used. Furthermore, all the respective applicable laws and ordinances associated with the transport, installation, starting up, operation, decommissioning and if necessary the disposal of the apparatus must be taken into consideration.

The process engineering design, strength calculations, manufacture and testing of the apparatus are based on the regulations given on the product data sheet.

To protect the apparatus against dirt suitable measures must be taken according to the degree of soiling (particle size, loading, etc.), e.g. installation of filters, sieves, etc. The apparatus is not suitable for products highly loaded with solids. It is therefore necessary to install a sieve or filter upstream of the apparatus.

Where steam condensers are used, the customer must provide a suitably dimensioned condensate drain pipe.

Abrupt changes in pressure and pressure shocks as well as dynamic loads must always be avoided (see Chapter I.3.).

Please ensure that you carefully read the instruction manual supplied with the apparatus before installing and starting it up. The specifications in the manual must be observed and applied.

2. Starting Up

You should always avoid running the apparatus with parameters such as temperatures, pressures, throughput quantities and media other than those given in the product data sheet and the order confirmation. Changes to these parameters required thermowave's consent; otherwise we will not accept any guarantee for operation.

Only start up the apparatus after you have checked whether the initial measure matches the information on the name plate and all the available protective covers have been installed. The protective covers also include the insulation hoods.

No sudden pressure and temperature changes may occur in the plant in which the plate heat exchanger is installed.

To protect the gaskets, pressure and temperature must be slowly applied to the properly installed apparatus (note the information in Chapter I.3).

Shut-off devices which are located behind the apparatus and possible draining devices must be open to avoid a sudden pressure load on the heat exchanger. Before starting up the shut-off devices arranged upstream of the apparatus must be closed. After switching on the pump the shut off devices may only be opened slowly so that the values given in Chapter I.3 are maintained. Purging devices must be closed after evacuating the air.

The apparatus should be insulated to prevent the formation of condensate or hoar frost when the ambient temperature of the apparatus falls below the melting point. We will be pleased to offer a suitable insulation for your apparatus.

Start-up of Evaporators (e. g. coolant evaporator)

When operating a module welded plate heat exchanger as evaporator the following instructions have to be taken into account before the start-up of the apparatus:

1. Visual control of the physical characteristics (dimensions) of the heat exchanger according to the specification in the data sheet.
2. Control of connections of the media according to the technical data sheet for connections.
3. Start-up of the refrigerating agent circuit (possibly by bypass)
4. **After** step 3 (**slow**) start-up of the refrigerant circuit
5. If the evaporator is going to be CIP-cleaned (Cleaning in Place) please consider chapter VI / 3.

3. Withdrawal from Service

Before switching off the pumps the shut-off devices located upstream of the plate heat exchanger must be closed **slowly**. If the shut off procedure is carried out too fast, sudden pressure loads can occur which can lead to leaks and damages to the gaskets (note the details given in Chapter I.3). After the apparatus has been brought to the **ambient temperature and ambient pressure**, it must be drained on both sides and then cleaned if necessary (see also Chapter VI).

4. Shutdown

Shutdowns (temporary or longer stoppages) are always periods of increased risk of corrosion!

If the apparatus is shutdown for a lengthy period, it must be drained. Depending on the cleaning process used, the plates must be carefully cleaned and rinsed before (CIP cleaning) or after (manual cleaning) their installation. When opening the apparatus, proceed according to Chapter V.1. When the

cleaning is finished the plate pack must be tightened again so that the plates are loose and the gaskets only lightly touch each other.

Before opening the apparatus note the initial measure of the plate pack to be able to tighten it by the correct measure when recommissioning the apparatus.

When running the apparatus with aqueous products or products at risk from frost the apparatus must always be drained before shutting it down for any length of time. In this context, please read and observe the instructions given in Chapter V.1.

5. Recommissioning (Following Shutdown)

Before recommissioning the condition of the plate pack must be checked. The gaskets must sit properly in the heat exchanger plates. The surfaces of the plates and gaskets must be free of dirt.

The tightening bolts must be tightened to at least the last initial measure. If the apparatus is not thoroughly tight, the plate pack can be tightened up to 3 % above this initial measure. In case the minimum initial measure has already been reached, please contact us (see Chapter I.3 for the address). You should never tighten the apparatus beyond the measure (final measure) given on the name plate.

thermowave's customer service department will always try to help its customers with all the questions and problems that may occur with the plate heat exchanger with qualitative and professional assistance.

6. Service and Maintenance

Due to the construction of the plate heat exchanger it is less susceptible to dirt than other heat exchangers, as the turbulences in the plate gaps can mostly prevent the accumulation of foreign matter.

However, dirt deposits cannot be avoided if media loaded with solids are used in the heat transfer process. The fouling layer formed is subject to the relatively high shear forces of the media flowing through the apparatus so that in many cases an equilibrium is reached between the deposits and the removal of dirt particles. If the plate heat exchanger has been appropriately dimensioned, it can continue to fulfil its heat transfer tasks despite soiling.

An increase in the pressure drop (> 20 %) or a reduction in the heat transfer output (> 10 %) beyond the values given in the product data sheet indicates that the plates are soiled. The apparatus must be cleaned so that it can produce its original output again.

Apart from the regular cleaning of the heat transfer surfaces, the threads of the tightening bolts must be protected against corrosion and damage by greasing or applying a suitable anticorrosion agent. You must always ensure that the easy movement of the thread is not impaired by coating (e.g. through paint, dirt, etc.) or mechanical damage. Corroded tightening bolts must be replaced, as these are an important pressure retaining part of the plate heat exchanger.

Any insulation on the apparatus must be fastened so that partial disassembly for regular safety inspections on the plate heat exchanger is possible.

Regular visual inspections must be carried out (at least annually), depending on the media used, the place of installation and other applicable regulations. The Visual Inspection Checklist in Appendix Z should be used for this purpose.

The necessary maintenance work on plate heat exchangers is usually limited to renewing used gaskets, as these are subject to ageing and therefore have a limited service life.

If a leak becomes visible in the plate pack during operation, the apparatus can be tightened in a depressurised condition up to the final measure given on the name plate. The sequence in accordance with Figure 6 must always be observed.

High operating temperatures cause faster ageing and under certain circumstances may require the gaskets to be replaced before the final measure is reached. This can be easily determined if further tightening fails to achieve additional tightness.

Our qualified service personnel professionally carry out renewal of the gaskets on request.

7. Defects Analysis

Experience in handling plate heat exchangers shows that faults can occur during the operational sequences. These can be caused by all kinds of different reasons.

A summary of the most frequent types of faults, the possible causes and the proper corrective measures is given in Table 2.

Of course, our company's Customer Service Department is also available to provide assistance at any time (see Chapter 1.3 for the address) to carry out any necessary corrective measures.

Type of defect	Cause of defect	Corrective measures
Increased pressure drop in the plate heat exchanger	Soiling of the plate heat exchanger	Clean pipes before start up Clean plates Filter media with suitable equipment
	Viscosity	Check viscosity and if necessary adjust to the prescribed values Check whether the temperatures fall below the minimum medium temperature during operation
	Incorrect connection to the pipe network	Check connection and carry out according to the drawing Turn the frame and / or plate gap; this is mostly possible, as our frame is designed to be symmetrical.
	Flow rate too high	Check flow rate and if necessary adjust to set point value
Reduced plate heat exchanger output	Soiling of the plate heat exchanger by foreign bodies (mechanical)	Clean plates Filter media with suitable equipment
	Flow rate too high	Check flow rate and if necessary adjust to set point value
	Incorrect connection to the pipe network	Check connections and carry out according to the drawing

	Accumulation of secondary media in the apparatus (e.g. oil, non-condensable gases, etc.)	Create suitable device for draining away the secondary media
Leakages	Max. permissible operating pressure exceeded	Reduce operating pressure to set point value
	Pressure shocks/ vibrational overstress	Stop pressure shocks or vibrations
	Max. permissible temperature exceeded, e.g. one-sided loading with hot media	Set working temperature to set point value Replace gaskets, if necessary use other gasket materials
	Chemical decomposition of the gaskets by media attack	Replace gaskets, if necessary use other gasket materials Install intermediate circuit
	Blockages	Remove blockage Clean plates Filter media with suitable equipment
Media mix	Plates incorrectly installed	Install plates and gaskets according to parts list
	Corrosion of the heat exchanger plates	Look for cause of corrosion and remove and install new plate pack Install new plate pack made of resistant material
	Incorrect connection to the pipe network	Check connections and carry out according to drawing Turn the frame and / or plate gap; this is mostly possible, as our frame is designed to be symmetrical.

Table 2

V. Installation and Removal of the Plate Pack

Safety information: Before opening and closing the plate pack, read Section I.2!!

Always wear suitable safety gloves when handling the plates. Due to the thin thickness of the plates there is a large risk of cuts!

1. Opening the Plate Pack

If the apparatus is in operation, carry out the steps in accordance with the instructions in the Section "Decommissioning" the plate heat exchanger (see Chapter IV.3).

After draining the apparatus and removing the protective covers, dismantle the pipes on the movable frame plate (if present) so that there is sufficient space to slide the cover up to the support.

The carrying bar and the thread of the tightening bolts must be cleaned to avoid canting of the plate pack during opening.

Before opening the apparatus, note the current initial measure of the plate pack, so you can tighten the plate pack to the correct value when recommissioning.

The tightening bolt nuts are unscrewed according to the sequence given in Figure 5. To achieve the greatest possible parallel relaxation of the plate pack, the nuts must be opened by 2 turns per operation. The process must be repeated in the given order until the tightening bolts can be removed from the clamping slots in the frame plates.

2. Removing the Plates

Slide the movable frame plate as far as possible towards the support.

Guide each of the plates individually into the area of the carrying bar at the support, which has a cut out. In this area the heat exchanger plates can be swung out to the side, due to the design of the lower carrying bar and then removed from the frame from below.

Set down the plates in the order you have removed them! To avoid subsequent mix-ups, we recommend that you number the plates in the correct sequence.

3. Installing the Plates

Before installing the plate pack the carrying bars, and the frame connections must be cleaned. The tightening bolts must be cleaned and greased, replaced if necessary.

The gaskets must fit well in the heat exchanger plates. Please ensure that the spaces between the gaskets and plates and the surfaces of the connections on the inside of the fixed and movable frame plate do not have any dirt deposits.

The plates are always installed in the reverse order to that in which they were removed.

Ensure that the plates are always installed in the sequence specified by the plate arrangement. This way your plate heat exchanger can give off the required output.

Slide the movable frame plate as far as possible towards the support.

Slide the plates, with the gasketed side pointing in the direction of the fixed frame plate, diagonally from below across the cut out in the upper carrying bar. Then swivel the lower end of the plate in the direction of the support above the lower carrying bar and slide the plate in the direction of the fixed frame plate until it touches against the last plate to be installed.

At the same time, the sequence according to the plate package parts list (starter plate, divider plate, end plate) must be observed!

4. Closing the Plate Pack

If necessary recheck whether the plates have been installed in the correct sequence.

Slide the movable frame plate as far as possible towards the plate pack and insert the tightening bolts in the tightening bolt slits. After slightly tightening them, recheck the correct fit of the gaskets. The basic rule of thumb is that they should have a uniform appearance to the plate pack.

The tightening bolt nuts are tightened in the sequence according to Figure 6. To achieve the best possible parallel movement of the plate pack, the nuts must only be tightened by max. 3 turns per operation. The procedure is repeated in the given order until the prescribed initial measure (see Chapter III.3 and IV.5) has been reached. Carry out a leak test before restarting the plate heat exchanger!

Opening the plate pack

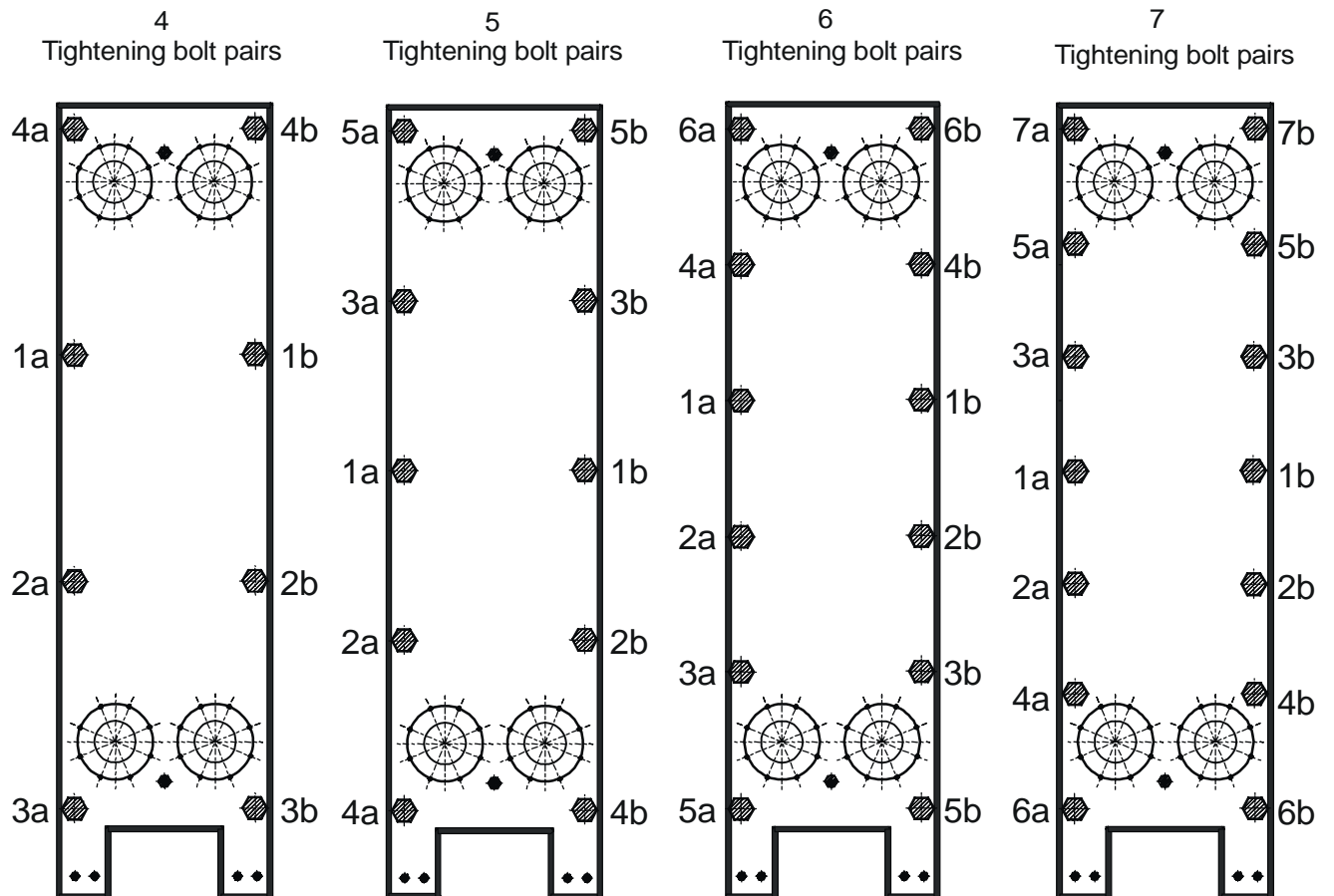

Procedure for undoing the bolts	Tightening bolt pairs			
	4	5	6	7
1 st step	4a and 4b	5a and 5b	6a and 6b	7a and 7b
2 nd step	3a and 3b	4a and 4b	5a and 5b	6a and 6b
3 rd step	2a and 2b	3a and 3b	4a and 4b	5a and 5b
4 th step	1a and 1b	2a and 2b	3a and 3b	4a and 4b
5 th step		1a and 1b	2a and 2b	3a and 3b
6 th step			1a and 1b	2a and 2b
7 th step				1a and 1b

Closing the plate pack

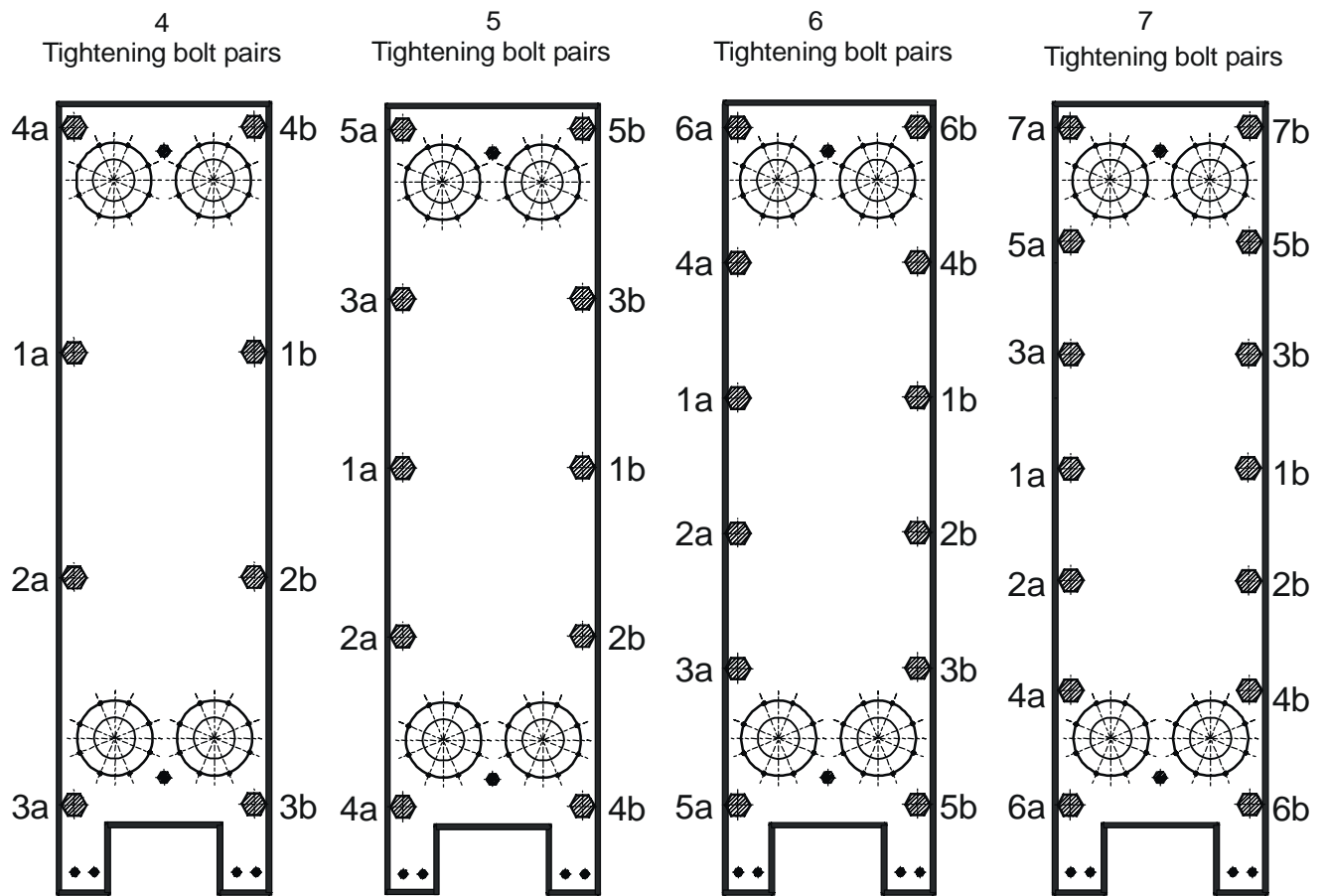

Procedure for tightening the bolts	Tightening bolt pairs			
	4	5	6	7
1 st step	1a and 1b	1a and 1b	1a and 1b	1a and 1b
2 nd step	2a and 2b	2a and 2b	2a and 2b	2a and 2b
3 rd step	3a and 3b	3a and 3b	3a and 3b	3a and 3b
4 th step	4a and 4b	4a and 4b	4a and 4b	4a and 4b
5 th step		5a and 5b	5a and 5b	5a and 5b
6 th step			6a and 6b	6a and 6b
7 th step				7a and 7b

VI. Cleaning

1. General

The plate heat exchanger can be cleaned in different ways depending on the degree of soiling and the technical plant possibilities.

A basic differentiation is made between CIP cleaning, in which the apparatus is not opened, and mechanical cleaning, which requires the apparatus to be opened.

2. Cleaning Laser Welded Modules

Several particular features must be noted when cleaning modules.

Modules consist of two LASER welded plates. Due to its design, some residual liquid always remains in the plate gap when they are loaded with liquid. This can only be removed with a large amount of effort (vacuum drying, etc.), as the plates are inseparably joined together.

- CIP cleaning on the laser welded side should therefore only be carried out if the remaining residues of the detergent are harmless for the subsequent applications. The plates must always be thoroughly rinsed after cleaning and the rinsing result monitored analytically if necessary.
- As the inside of the module is not accessible for mechanical cleaning, it cannot be cleaned manually. Where possible, the outside should only be cleaned manually if the modules are still hanging in the frame or are vertical e.g. to the wall. The modules should preferably be cleaned in the position shown in Figure 7. At the same time you must ensure that the detergent cannot get inside the modules. To this end the modules openings must be closed by a suitable means. A high pressure cleaner (jetting) should only be used if detergent in the laser welded gap is harmless.

It is very important that you ensure that no detergent and no loosened dirt can get into the laser welded plate gap of the module.

Stubborn dirt stuck fast in or on the modules must be removed according to the case-by-case specifications of our service personnel. Please contact **thermowave's** Customer Service Department for enquiries concerning this type of cleaning (see Chapter I.3 for the address).

Inlet and outlet openings for laser welded gap

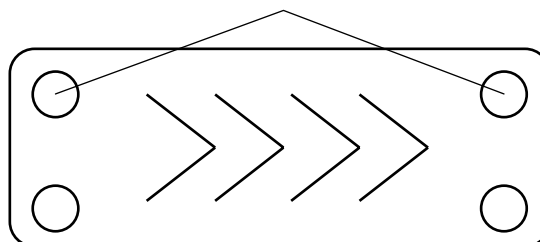

3. CIP – cleaning (Cleaning in Place)

If the plate pack is to be cleaned while closed, the necessary plant prerequisites must be created, e.g. the installation of appropriate pipe connections, valves, collecting containers, etc. for the preparation, storage and transport of the detergent.

The detergent used must not contain any components which attack the plate material and the gaskets used. When using ready-made, proprietary cleaning chemicals the manufacturer's instructions must also be observed, e.g.

- Concentration of detergent
- Specifications for the temperature regime according to the application
- Sequence of use of different chemicals (basic, acidic)
- Flushing and passivation specifications (especially when shutting down after cleaning).

In CIP cleaning the deposits are released from the plates by pumping around a suitable detergent and then flushed out of the apparatus. To achieve a satisfactory result, the flow rate of detergent should be greater than the rate during normal operation (at least 1.5 times more).

Following the actual cleaning sequence the detergent is removed from the apparatus after flushing with clean, chemically neutral water. If concentrated detergents are used subsequent passivation should be carried out using an oxidising acid (e.g. 2 % nitric acid solution). The apparatus must then be rinsed again thoroughly with plenty of water.

The changes in temperature which occur in the plate heat exchanger during CIP cleaning due to the process are inoffensive with regard to the guidelines in the order documentation (see e.g. chapter I.3).

The maximum permissible operating temperature, indicated on the nameplate, may in no case be exceeded. This applies also to any steaming procedure (only saturated steam to be used!) and hot rinsing.

Before the heat exchanger may be loaded with hot rinsing solution or hot water for CIP cleaning of the side of the service medium of evaporators, it is essential to suck the refrigerant completely off the apparatus. Otherwise the plate heat exchanger can be seriously damaged when the refrigerant evaporates explosively and therewith provokes a pressure increase on the refrigerant side.

Further information about the use of a CIP method is available from thermowave's Customer Service Department (see Chapter I.3 for the address) or a specialised cleaning company.

4. Manual Cleaning

Due to its flexible design principle, the plates of the plate heat exchanger can also be cleaned manually with a relatively small amount of work.

To do this, open the plate pack in accordance with the specifications given in Chapter V.1.

Slide the plates so that there is sufficient space between the plates for the cleaning work and a visual inspection.

Gaskets which are not glued in place must be removed from the plates. Ensure that you are careful not to tear off the pins.

The dirt can be removed by washing the plates with plenty of washing liquid and by brushing them (only use soft brushes!).

In case of stubborn or dried on deposits the adhering dirt must be softened first. Stubborn dirt stuck fast in or on the modules must be removed on a case-by-case basis by our service personnel. To this end, please contact thermowave's Customer Service Department (see Chapter I.3 for the address).

To do this, the plates are removed (see Chapter V.2 and V.3) and placed in cleaning baths at the correct temperature. Please ensure that the plates in cleaning baths are not damaged by corrosion due to the detergents and concentration and temperature used. When using a jetter for cleaning the plates, the cleaning jet should impinge upon the plate surface perpendicularly to avoid damage to the gaskets.

After cleaning any gaskets removed must be placed back in the plates. It is important to ensure that there is no dirt between the gasket and heat transfer plate. The plates must be re-installed according to the specifications given in Chapter V.2 and V.3.

thermowave's Customer Service Department (see Chapter I.3 for address) will be pleased to help you with any soiling problems. It may also be advisable to obtain information from a specialised cleaning company.

After completing the cleaning work the plate pack must be properly closed again (see Chapter V.4).

Plate Apparatus Nomenclature

TL 500 K B C L

TL: ThermoLine

Plate size
(HT-surface per plate
m² x 1000)

90 :	0.09 m²
150 :	0.15 m²
250 :	0.25 m²
400 :	0.40 m²
500 :	0.50 m²
650 :	0.65 m²
850 :	0.85 m²

Frame design

H : Frame without front support ¹⁾

K : Standard frame

N : Two equally long carrying bars

T : Special frame - low design

Nominal Pressure

A : PN 6

B : PN 10

C : PN 16

D : PN 25

E : PN 32

F : PN 40

Nominal width

A : DN 25

B : DN 32 ²⁾

C : DN 40

D : DN 50 ²⁾

E : DN 65 ²⁾

F : DN 80

G : DN 100

H : DN 125 ²⁾

I : DN 150

J : DN 175 ²⁾

K : DN 200

L : DN 250 ²⁾

M : DN 300 ²⁾

X : Special desg.

Frame construction

L : Painted carbon steel

V : Carbon steel covered with stainless steel

N : Solid stainless steel

X : Special design

¹⁾ only TL 90 and TL 150

²⁾ on request

Enclosure Z: Documentation of plate heat exchanger

1. Visual Inspection Checklist

Object of inspection	Solution
Soils on the outside	Clean the outside of the plate heat exchanger
Missing or illegible vessel-/ name plate	Order new vessel-/ name plate at the manufacturer
Corrosion of tightening bolts / nuts	Grease tightening bolts / nuts and / or renew or if necessary change corrosion prevention temporarily Check surrounding conditions
Corrosion of frame plates / pipe unions / pressure retaining connecting parts	Apply paint / corrosion prevention if necessary contact thermowave, check surrounding conditions
Control of the first measure	Tighten the tightening bolts if necessary (see chapter IV, item 6)
Leakage on the gasket of the plate heat exchanger	Tighten the plate pack to the maximum final measure according to the vessel name plate, renew gaskets if necessary and possibly contact thermowave
Leakage on the flange gasket	Tighten the flange, if necessary change the flange gasket
Leakage (to the outside) at modules on the laser weld	Change modules, imperatively contact thermowave
Leakage on the lining of nozzles	Find cause, change the lining and possibly contact thermowave